

Heater Core Combing Process.

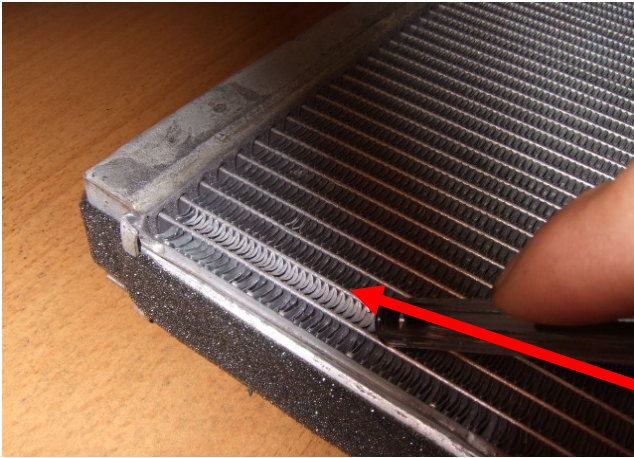

Instruction:

Remove Heater Core matrix from the HVAC/Heater Assembly as per the GTR process (80.20.29) and ensure that it is orientated as per the photo above before commencing the Combing Process detailed over leaf.



Comb ONLY
the SECOND
row of Fins
from the edge
of the core

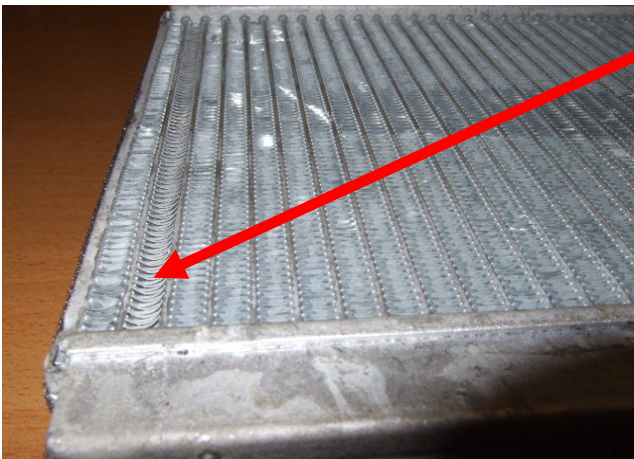

Instruction:

Using a small round tipped item such as a pencil top (fins are approximately 4mm across), **CAREFULLY** Comb down the second row of fins in from the left hand edge (only comb the second row in). **NB** as these fins are **VERY DELICATE, VERY LIMITED** pressure is required.

•Ensure that the core is not damaged when the fins are combed

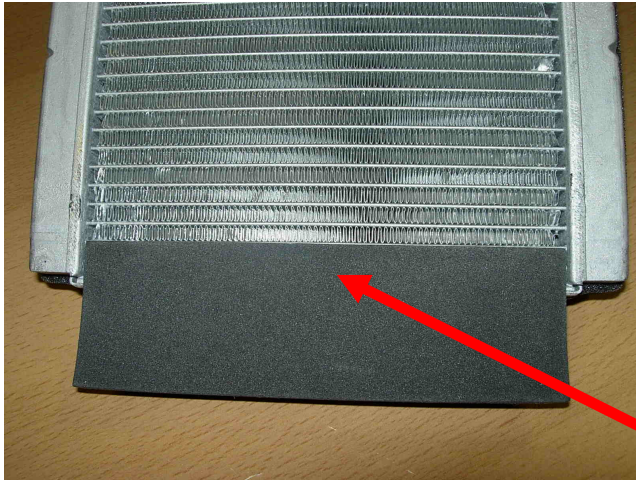

**Attach seal
to last 2
rows of
Heater Core**



Instruction:

Peel off the backing of the seal, and attach it to the last 2 rows of the Heater Core – NB the seal folds around the edge of the Heater Core. (Seal can be obtained upon submission of an EPQR, refer to SSM text)

•Ensure that the Core and Fins are free from Dirt or Grease and ensure that the Seal is stuck down firmly and securely.

Re-assemble Heater Core back in the HVAC/Heater Assembly as per the process in GTR (80.20.29).

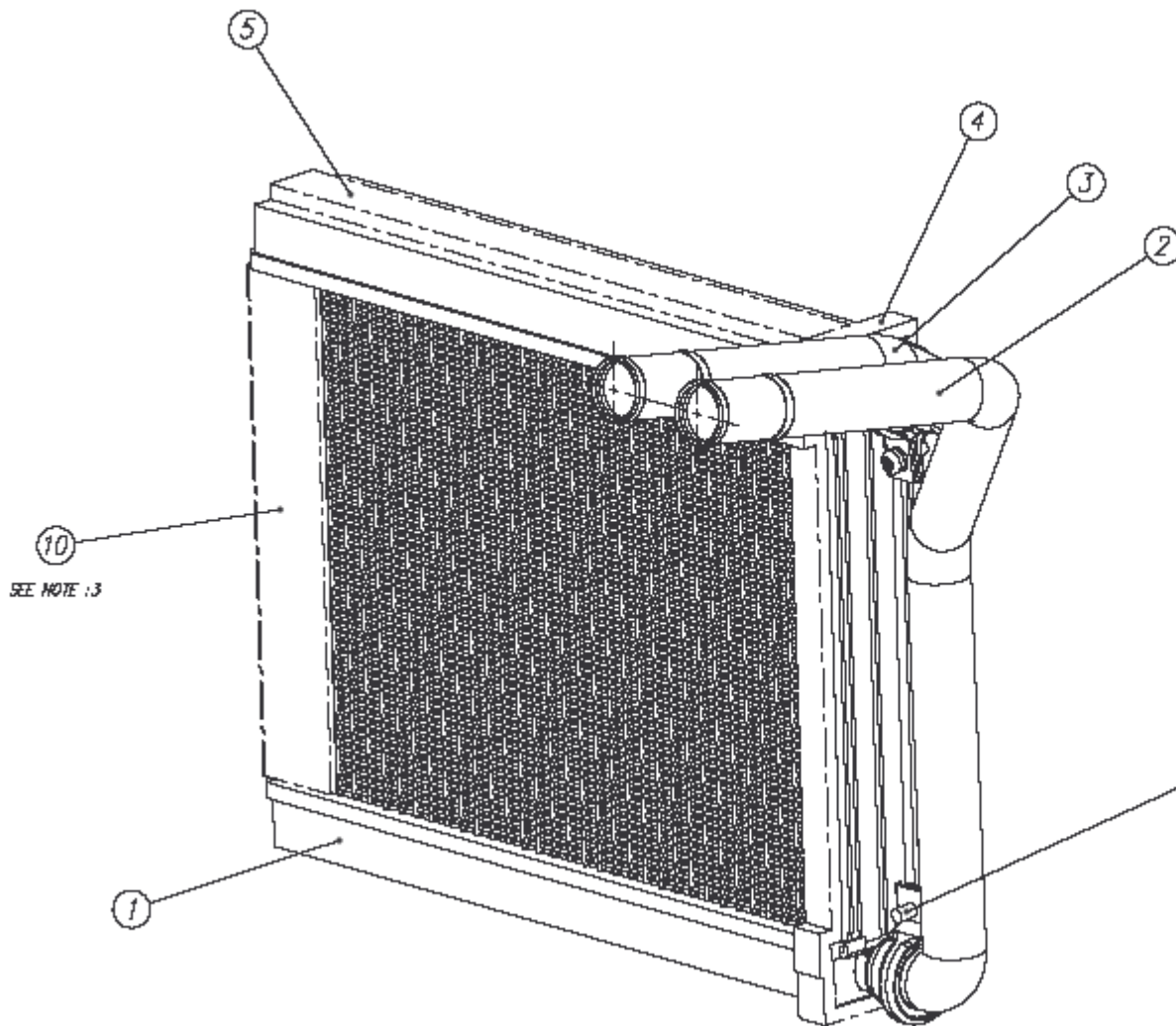

SEE NOTE 3

<i>ITEM</i>	<i>DESCRIPTION</i>
1	HEATER CORE
2	MANIFOLD INLET
3	MANIFOLD OUTLET
4	SEAL INSULATION
5	SEAL INSULATION
6	CLIP HEATER PIPES
7	SCREW M4 W/WASHER 913700-4101
8	GUIDE BUSHING
9	O-RING
10	SEAL HEATER CORE FINS

6 7 8 9

Note 3: Item 10 - Seal to cover 2 rows of Fins.